

14

Substation fittings

- › Busbar Support Clamps
- › Flat Busbar to Busbar Connectors
- › Straight Busbar to Busbar Connectors
- › Reducers Busbar to Busbar
- › Tee Connectors Busbar to Busbar
- › Straight Busbar to Palm Connectors
- › Right Angle Busbar to Palm Connectors
- › Straight Busbar to Conductor Connectors
- › Tee Connectors Busbar to Conductor
- › Straight Conductor to Conductor Connectors
- › Tee Connectors Conductor to Conductors
- › Straight Conductor to Palm Connectors
- › Right Angle Conductor to Palm Connectors
- › Straight Stud to Palm Connectors
- › Palmless Connectors
- › Flat Busbar Connectors

Aluminium Busbar Support Clamps

Type ABS



Busbar support clamps are cast to size in Aluminium Alloy and fitted with stainless steel bolts. Clamps may be converted from clamping to sliding type or vice versa, by simply reversing the cap.

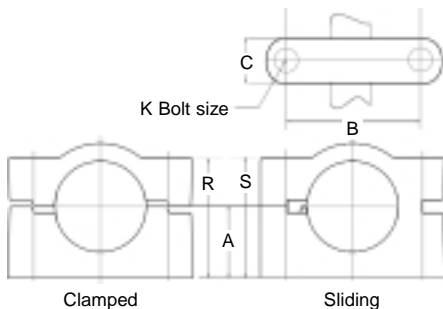

Cat. No.	O.D. Tube mm	Dimensions mm					
		A	B	C	K	R	S
ABS15	12.7	21	76	25	M12	37	38
ABS17	15.9	23	51	25	M10	36	37
ABS25	19.1	25	76	25	M12	41	42
ABS30	25.4	25	51	32	M10	41	46
ABS35	25.4	25	76	38	M12	46	51
ABS40	31.8	27	51	38	M10	46	51
ABS42	41.3	33	76	38	M12	56	59
ABS45	31.8	29	76	38	M12	52	54
ABS50	38.1	32	51	32	M10	57	59
ABS55	38.1	33	76	38	M12	57	59
ABS60	50.8	40	76	38	M12	70	72
ABS65	57.2	43	76	38	M12	76	78
ABS70	60.3	43	76	38	M12	76	79
ABS75	63.5	54	127	51	M16	98	100
ABS80	80.0	54	127	51	M16	103	105
ABS85	76.2	54	127	51	M16	103	105
ABS100	88.9	60	127	51	M16	110	111
ABS102	100.0	61	127	51	M16	110	112

Fittings on this page have a minimum current rating, in line with the maximum Australian Standard conductor size or busbar size that the fitting can accept.

Busbar Support Clamp

Type BS - Copper

Busbar support clamps are cast to size in high strength copper alloy. Standard bolts are stainless steel. Clamps may be converted from clamping to sliding type or vice versa, by simply reversing the cap.

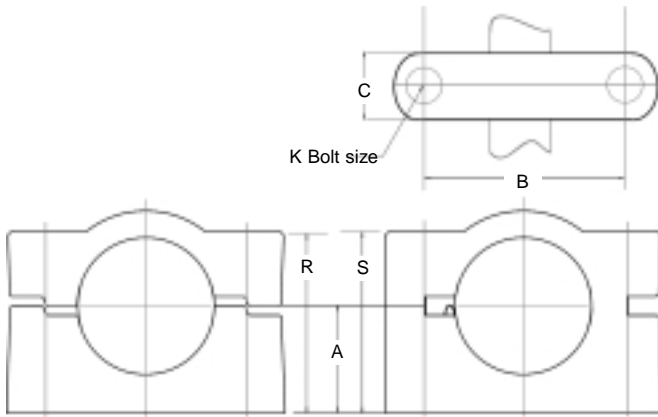
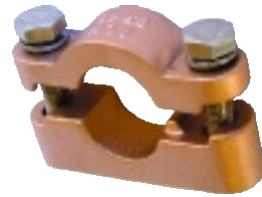

Cat. No.	O.D. Tube mm	Dimensions mm					
		A	B	C	K	R	S
BS5	6.35	14.0	50.8	25.4	M10	25.4	26.9
BS10	12.70	19.0	50.8	28.5	M10	31.7	33.3
BS15	12.70	19.0	76.2	28.5	M12	36.5	38.1
BS17	15.88	22.0	50.8	25.4	M10	38.1	36.5
BS20	19.05	22.0	50.8	28.5	M10	34.9	36.5
BS25	19.05	25.4	76.2	28.5	M12	39.7	41.2
BS30	25.40	25.4	50.8	28.5	M10	46.0	47.6
BS35	25.40	25.4	76.2	28.5	M12	41.2	42.8
BS40	31.75	28.5	50.8	28.5	M10	49.2	50.8
BS45	31.75	28.5	76.2	28.5	M12	42.8	44.4
BS50	38.10	31.7	50.8	28.5	M10	53.9	55.5
BS55	38.10	31.7	76.2	28.5	M12	49.2	50.8
BS60	50.80	38.0	76.2	28.5	M12	68.2	69.8
BS70	63.50	44.5	127.0	31.7	M16	82.5	84.1

Note: Adaptor plate part No. E8045 available to suit 127mm PCD insulators and above BS type connectors.

Fittings on this page have a minimum current rating, in line with the maximum Australian Standard conductor size or busbar size that the fitting can accept.

Substation Fittings

Tube Connector Busbar to Flat

Type TF - Copper; ATF - Aluminium

These connectors provide an inexpensive tube to flat termination. They also combine with the flexible braid connections to provide expansion joints between tubes in lines, tubes at right angles and between tube and flat terminals. Connectors can be supplied with stainless steel bolts and nuts.

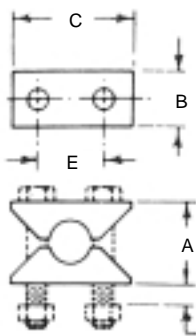

Fig. 1

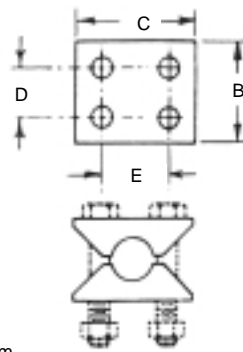

Fig. 2

Cat. No.		O.D. Tube mm	Fig. No.	Dimensions mm					Bolt Size
Without Bolts	With Bolts			A	B	C	D	E	
TF10	TF10B	12.7	1	32	25	54	---	29	M10
TF15	TF15B	15.9	1	32	25	54	---	29	M19
TF20	TF20B	15.9	2	32	48	54	22	29	M10
TF25	TF25B	19.1	1	38	25	57	---	32	M10
TF30	TF30B	19.1	2	35	48	57	22	32	M10
TF34	TF34B	25.4	1	44	22	57	---	38	M10
TF35	TF35B	25.4	1	44	29	60	---	38	M10
TF40	TF40B	25.4	2	41	48	60	22	38	M10
TF45	TF45B	25.4	2	41	54	64	29	38	M10
TF4522	TF4522B	25.4	2	40	76	76	51	51	M10
TF45A	TF45AB	27.0	2	43	54	64	29	38	M10
TF46	TF46B	28.6	1	44	29	60	---	38	M10
TF47	TF47B	28.6	2	44	54	64	29	38	M10
TF49	TF49B	30.0	2	46	54	70	29	44	M10
TF50	TF50B	31.8	2	48	54	70	29	44	M12
TF52	TF52B	34.0	2	51	54	70	29	44	M10
TF53	TF53B	35.0	2	51	54	70	29	44	M10
TF54	TF54B	38.1	1	57	22	70	---	51	M10
TF55	TF55B	38.1	2	54	54	76	29	51	M10
TF56	TF56B	38.1	2	60	76	83	44	54	M12
TF57	TF57B	40.0	2	56	55	76	29	51	M10
TF60	TF60B	48.0	2	64	57	83	29	57	M10
TF65	TF65B	50.8	2	67	54	89	29	64	M10
TF67	TF67B	60.0	2	80	54	98	29	73	M10
TF70	TF70B	63.5	2	84	54	105	29	80	M10
TF75	TF75B	76.2	2	95	54	114	29	89	M10

Note: To order in aluminium, add prefix 'A' to catalogue number.

Fittings on this page have a minimum current rating, in line with the maximum Australian Standard conductor size or busbar size that the fitting can accept.

Substation Fittings

Tube Connector

Type PTC - Copper

For the connection of tubular busbar to switchgear terminal plates with four 14mm diameter holes at 50mm centres. Two PTC connectors are required per termination. Materials: High copper content alloy castings. Stainless steel bolts, washers and nuts.

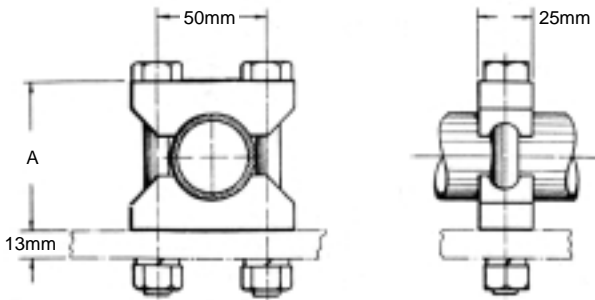

Cat. No.	O.D. Tube mm	Dimension A
		mm
PTC4010	25.4	52
PTC4012	30.2	57
PTC4020	38.1	68

Fittings on this page have a minimum current rating, in line with the maximum Australian Standard conductor size or busbar size that the fitting can accept.

Aluminium Straight Connector Busbar to Busbar Type AST

Type AST straight connectors are cast to size in high strength aluminium alloy and fitted with stainless steel bolts and nuts. Both connector halves are identical.

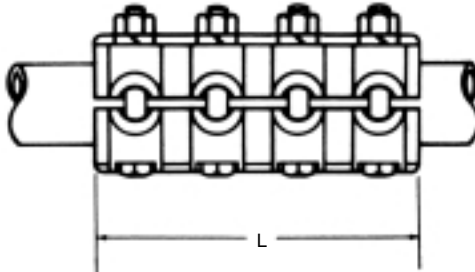

Cat. No.	O.D. Tube mm	Length L mm	Bolt Size
AST5	19.1	105	M10
AST20	25.4	127	
AST35	31.8	152	
AST50	38.1	152	
AST85	50.8	178	
AST86	57.2	191	M12
AST88	60.3	191	
AST90	63.5	191	
AST95	76.2	216	
AST80M	80.0	178	
AST100	88.9	216	
AST100M	101.6	184	

Fittings on this page have a minimum current rating, in line with the maximum Australian Standard conductor size or busbar size that the fitting can accept.

Straight Connector Busbar to Busbar Type ST - Copper

This heavy duty connector is cast to size. The minute surface projections provide a multiple point high pressure contact which gives a low resistance joint. Both connector halves are identical. Connectors are supplied with stainless steel bolts, nuts and spring washers.



Fig. 1

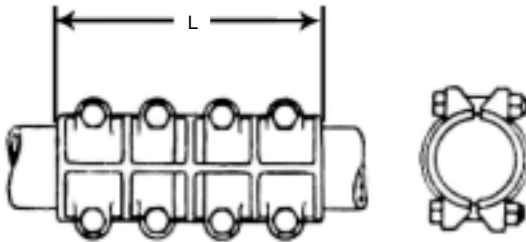

Fig. 2

Cat. No.	O.D. of Tube mm	Fig.	Dimension L mm	Bolt Size
ST5	19.1	1	70	M10
ST20	25.4	1	83	M12
ST20C	25.4	2	127	M10
ST27	28.6	2	140	M10
ST35	31.8	1	102	M12
ST50	38.1	1	102	M12
ST85	50.8	2	159	M12
ST95	76.2	2	229	M12

Fittings on this page have a minimum current rating, in line with the maximum Australian Standard conductor size or busbar size that the fitting can accept.

Reducer Busbar or Studs

Type RS - Copper

The type RS reducer is designed for use with solid copper busbar tube and equipment studs.

Materials: High copper content alloy casting. Stainless steel bolts, washers and nuts.

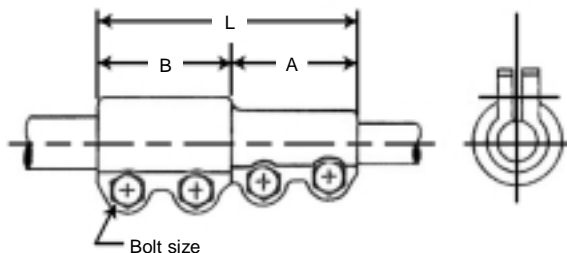

Cat. No.	O.D. of Tube mm		Dimensions mm			Bolt Size
	Run	Tap	A	B	L	
RS1110	28.6	25.4	57	51	108	M10
RS1210	30.2	25.4	57	51	108	M10
RS1508	38.1	22.2	60	57	117	M10
RS1509	38.1	25.0	60	57	117	M10
RS1511	38.1	28.6	60	54	114	M10
RS1512	38.1	30.2	60	54	114	M10
RS1514	38.1	34.9	60	54	114	M10
RS1610	39.7	25.4	60	57	117	M10
RS1818	44.5	44.5	76	76	152	M12

Fittings on this page have a minimum current rating, in line with the maximum Australian Standard conductor size or busbar size that the fitting can accept.

Reducer Busbars

Type RT - Copper

The type RT is a two piece design suitable for use with tubular busbar. It is cast in high copper content alloy and fitted with stainless steel bolts, nuts and spring washers.

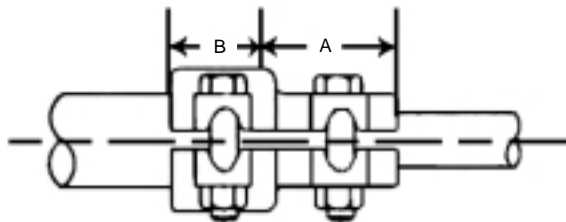
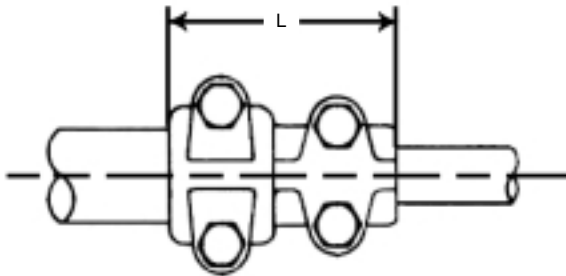

Cat. No.	O.D. of Tube mm		Dimensions mm			Bolt Size
	Run	Tap	A	B	L	
RT15	25.4	19.1	44	35	79	M10
RT30	31.8	19.1	48	32	79	M10
RT32C	31.8	25.4	57	56	114	M10
RT45	38.1	25.4	51	51	102	M12
RT47	38.1	30.2	51	51	102	M12
RT60	44.5	25.4	54	44	98	M12
RT65	44.5	31.8	62	46	108	M12
RT75	50.8	25.4	54	44	98	M12
RT80	50.8	38.1	64	48	111	M12
RT90	76.2	38.1	64	51	114	M12

Fittings on this page have a minimum current rating, in line with the maximum Australian Standard conductor size or busbar size that the fitting can accept.

Aluminium Tee Connector Busbar to Busbar

Type ATT

Type ATT tee connectors are cast to size in high strength aluminium alloy. Both connector halves are identical. Supplied with stainless steel bolts and nuts.

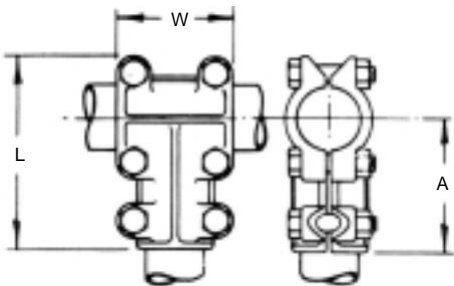

Cat. No.	Conductor Range OD mm		Dimensions mm			Bolt Size
	Run	Tap	A	L	W	
ATT28	28.6	25.4	75	111	44	M10
ATT35	31.8	31.8	108	152	83	M12
ATT3830	38.1	30.0	106	149	86	M12
ATT50	38.1	38.1	111	156	90	M12
ATT75	50.8	25.4	108	159	76	M12
ATT2020	50.8	50.8	127	178	102	M12
ATT2410	60.3	25.4	114	171	89	M12
ATT2413	60.3	31.8	114	171	102	M12
ATT2415	60.3	38.1	114	171	102	M12
ATT88	60.3	60.3	133	187	108	M12
ATT89	63.5	63.5	137	191	121	M12
ATT93	76.2	50.8	130	194	99	M12
ATT95	76.2	76.2	175	238	114	M12
ATT8064	80.0	63.5	184	248	114	M12
ATT8080	80.0	80.0	175	238	114	M12
ATT99	88.9	50.8	143	222	105	M12
ATT100	88.9	60.3	146	219	108	M12
ATT3535	88.9	88.9	197	270	146	M12
ATT10060	100.0	60.3	201	282	127	M16
ATT10080	100.0	80.0	202	283	143	M16
ATT100100	100.0	100.0	305	283	143	M16
ATT4525	114.3	63.5	194	292	117	M12
ATT11480	114.3	80.0	210	298	152	M16
ATT4533	114.3	82.6	210	298	152	M16

Fittings on this page have a minimum current rating, in line with the maximum Australian Standard conductor size or busbar size that the fitting can accept.

Tee Connector Conductor to Conductor Type TT - Copper

This heavy duty connector is cast to size. The minute surface projections provide a multiple point high pressure contact which gives a low resistance joint. Both connector halves are identical. Connectors are supplied with stainless steel bolts and nuts. Refer to table on adjoining page for conductor ranges and dimensions.



Fittings on this page have a minimum current rating, in line with the maximum Australian Standard conductor size or busbar size that the fitting can accept.

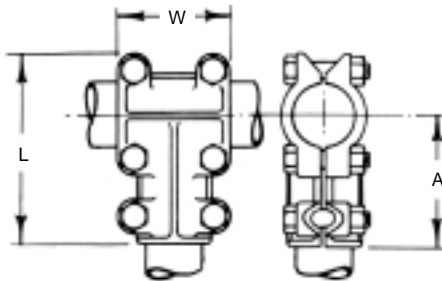

Fig. 2

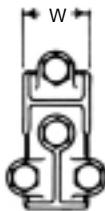

Fig. 1

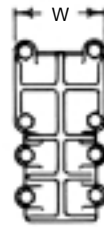

Fig. 3

Tee Connector

Type TT - Copper

Cat. No.	O.D. of Tube mm		Fig. No.	Dimensions mm			Bolt Size
	Run	Tap		A	L	W	
TT3	15.9	15.9	1	55	80	35	M10
TT5	19.1	19.1	1	57	83	38	M10
TT7	20.6	20.6	1	57	83	38	M10
TT10	19.1	25.4	1	68	98	44	M12
TT15	25.4	19.1	1	62	92	38	M10
TT17	22.2	20.6	1	68	98	44	M12
TT20	25.4	25.4	1	70	103	43	M12
TT20C	25.4	25.4	2	68	98	76	M10
TT21	28.6	28.6	1	71	107	44	M12
TT25	25.4	38.1	1	87	121	44	M12
TT27	28.6	15.9	2	73	108	50	M10
TT28	30.2	25.4	1	75	111	44	M12
TT30	31.8	19.1	1	64	95	44	M10
TT32	31.8	25.4	1	75	111	44	M12
TT35	31.8	31.8	1	76	114	44	M12
TT40	31.8	44.5	2	102	138	86	M12
TT45	38.1	25.4	1	76	117	50	M12
TT45C	38.1	25.4	2	76	114	92	M10
TT50	38.1	38.1	2	105	146	83	M12
TT50C	38.1	38.1	2	80	117	92	M10
TT55	38.1	50.8	2	110	149	97	M12
TT60	44.5	25.4	1	80	124	50	M12
TT65	44.5	31.8	1	110	156	73	M12
TT70	44.5	44.5	2	110	154	89	M12
TT75	50.8	25.4	1	84	133	50	M12
TT78	48.4	31.8	2	102	151	90	M12
TT79	50.8	31.8	2	102	151	90	M12
TT80	50.8	38.1	2	108	157	90	M12
TT83	48.4	50.8	2	116	164	95	M12
TT84	48.4	48.4	2	116	164	95	M12
TT85	50.8	50.8	2	116	162	95	M12
TT86	54	50.8	2	116	168	95	M12
TT88	63.5	38.1	2	114	168	95	M12
TT90	76.2	38.1	2	114	178	83	M12
TT95	76.2	76.2	3	156	216	95	M12
TT100	88.9	60.3	2	140	211	109	M12

Aluminium Terminal Lug Busbar to Palm Type ABT

For terminating tubular aluminium busbar at switchgear palms. Castings are in high strength aluminium. Bolts and nuts are stainless steel.

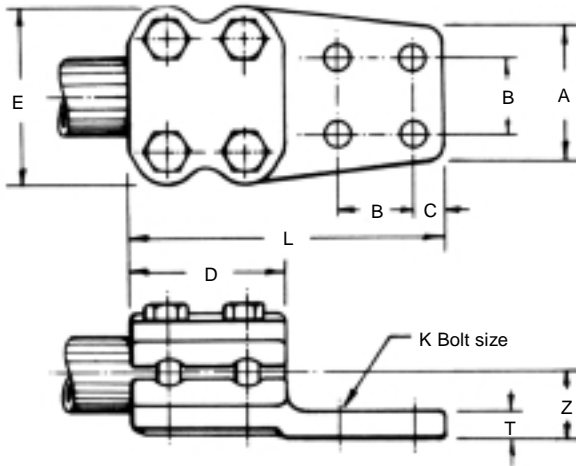

Cat. No.	O.D. Tube mm	No. of holes in Palm	Dimensions mm								
			A	B	C	D	E	K	L	T	Z
ABT20	25.4	38	38	16	83	83	M12	162	10	32	2
ABT30	31.8	38	38	16	83	83	M12	162	10	32	2
ABT40	38.1	67	38	16	76	86	M12	156	11	35	4
ABT50	50.8	83	50	16	76	100	M12	165	14	42	4
ABT54	57.2	83	---	---	80	105	---	168	14	44	---
ABT57	60.3	83	---	---	83	108	---	171	14	46	---
ABT63	61.0	83	50	30	83	100	M12	172	14	46	2
ABT64	63.5	83	50	16	83	100	M12	172	14	46	4
ABT80	80.0	83	50	15	83	130	M12	172	16	57	4
ABT95	76.2	83	---	---	83	171	---	172	16	55	---
ABT105	88.9	102	---	---	83	140	---	184	14	61	---

Note: Details of unlisted sizes available on request.

Fittings on this page have a minimum current rating, in line with the maximum Australian Standard conductor size or busbar size that the fitting can accept.

Substation Fittings

Terminal Lug Busbar to Palm

Type BT - Copper



Designed for tube to flat connections. Castings are of high copper content alloy. Lugs are machined on underside. Lugs are supplied with stainless steel bolts and nuts. Note type BT20A is machined on both sides of the lug.

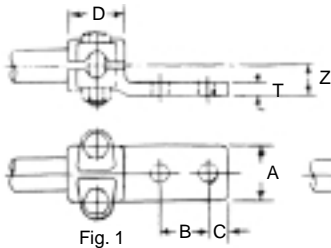

Fig. 1

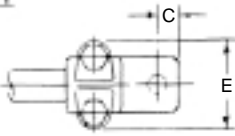

Fig. 2

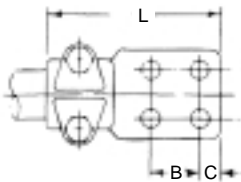

Fig. 3

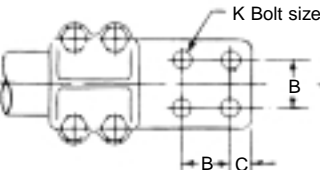

Fig. 4

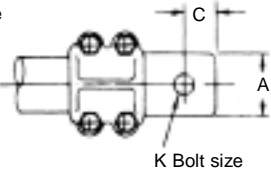

Fig. 5

Cat. No.	O.D. Tube mm	Fig. No.	Dimensions mm								
			A	B	C	D	E	L	K	T	Z
BT2	12.7	2	29	---	14	32	38	64	M10	6	16
BT3	15.9	2	32	---	16	32	49	70	M10	10	16
BT5	19.1	2	32	---	16	35	52	73	M12	10	20
BT10	19.1	1	33	29	13	35	52	94	M10	10	20
BT20	25.4	1	41	38	16	44	67	121	M12	10	23
BT20A	25.4	5	38	---	19	51	59	108	M12	6	16
BT30	31.8	1	48	38	16	51	59	127	M12	10	26
BT33	33.3	3	70	38	16	51	76	130	M12	10	30
BT40	38.1	3	70	38	16	51	80	130	M12	11	30
BT46	46.0	4	70	38	16	64	89	146	M12	11	37
BT50	50.8	4	70	38	16	70	95	152	M12	11	37

Fittings on this page have a minimum current rating, in line with the maximum Australian Standard conductor size or busbar size that the fitting can accept.

Right Angle Aluminium Terminal Lug Busbar to Palm Type ABT-L

Designed for terminating tubular aluminium busbar at right angles to the contact surface. Castings are in high strength aluminium. Bolts and nuts are stainless steel.

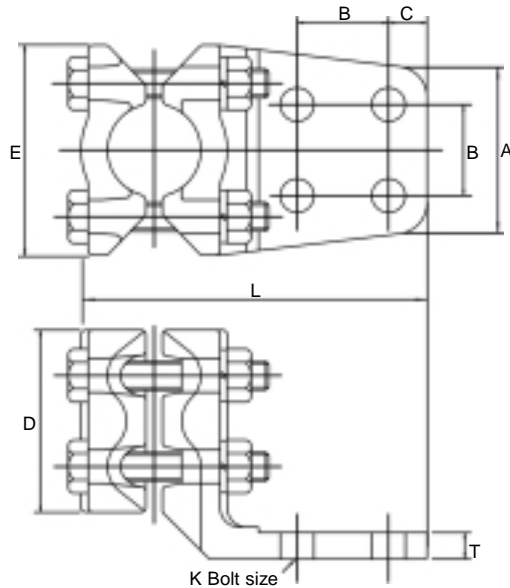

Cat. No.	O.D. Tube mm	No. of holes in Palm	Dimensions mm							
			A	B	C	D	E	L	K	T
ABT30L	31.8	2	67	38	16	83	81	156	M12	13
ABT40L	38.1	4	67	38	16	76	87	143	M12	13
ABT57L	60.3	---	83	---	---	79	105	185	---	14
ABT250L	63.5	4	89	38	25	89	111	216	M12	14

Note: Details of unlisted sizes available on request.

Fittings on this page have a minimum current rating, in line with the maximum Australian Standard conductor size or busbar size that the fitting can accept.

Substation Fittings

Right Angle Terminal Lug Busbar or Stud to Palm Type LS - Copper

For the connection of vertical tubular busbar to switchgear terminal plates. Bolts, nuts and spring washers are stainless steel.

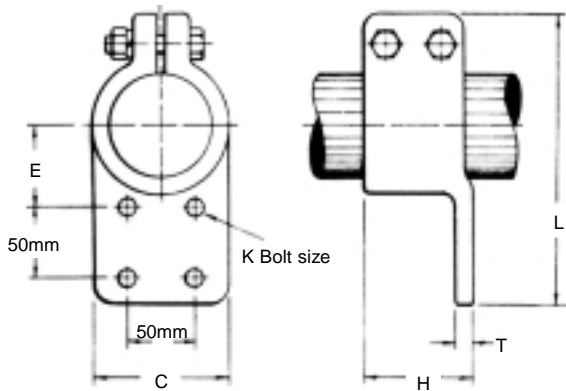

Cat. No.	O.D. Tube mm	Dimensions mm					
		C	E	H	L	T	K
LS5	19.1	79	35	44	133	10	M12
LS7	22.2	79	35	44	133	10	M12
LS20	25.4	76	41	64	143	10	M12
LS20C	25.4	102	57	64	171	13	M12
LS25	30.2	102	67	76	184	19	M12
LS25C	30.2	102	57	64	171	13	M12
LS28A	30.2	140	75	76	235	13	M16
LS30	31.8	83	43	64	146	13	M12
LS40	38.1	102	57	60	184	13	M12
LS50	50.8	102	60	73	193	13	M12
LS54	57.2	102	73	76	200	13	M12
LS95	76.2	102	67	83	216	13	M12
LS2018	30.2	76	54	64	143	10	M10

Fittings on this page have a minimum current rating, in line with the maximum Australian Standard conductor size or busbar size that the fitting can accept.

Aluminium End Connector Busbar to Conductor

Type AE - Tube to Conductor

A heavy duty tube-to-conductor end connector. The adjustable tap takes a large range of conductors which may be clamped before attaching to tubular bus.

Materials: Cast aluminium alloy body, stainless steel bolts, U-bolts, washers and nuts.

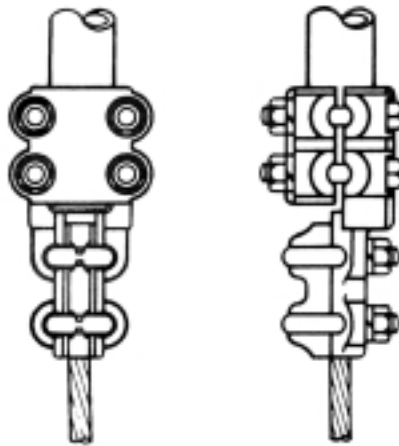

Cat. No.	O.D. Tube mm	Range for Aluminium & Cu Cond.	
		mm ²	Dia. Range
AE1065	25.4	70 - 150	10.70 - 15.75
AE1265	30.2		
AE1365	31.8		
AE1565	38.1		
AE3065	76.2		
AE12102	30.2	240 - 400	20.25 - 25.65
AE13102	31.8		
AE14102	34.9		
AE15102	38.1		
AE80M837	80.0		
AE80M102	80.0	240 - 400	20.25 - 25.65
AE10837	25.4	150 - 240	15.75 - 20.25
AE60837	60.0		
AE15117	38.1	400 - 500	25.65 - 28.80
AE35837	88.9	150 - 240	15.75 - 20.25
AE2550	25.4	35 - 95	7.65 - 12.46

Fittings on this page have a minimum current rating, in line with the maximum Australian Standard conductor size or busbar size that the fitting can accept.

End Connector Busbar to Conductor

Type E - Copper, for connecting tube to conductor



A heavy duty tube-to-conductor end connector. The adjustable tap takes a large range of conductors which may be clamped before attaching to tubular bus.

Materials: High copper content alloy casting with stainless steel bolts, U-bolts, washers and nuts. Fittings on this page have a minimum current rating, in line with the maximum Australian Standard conductor size or busbar size that the fitting can accept.

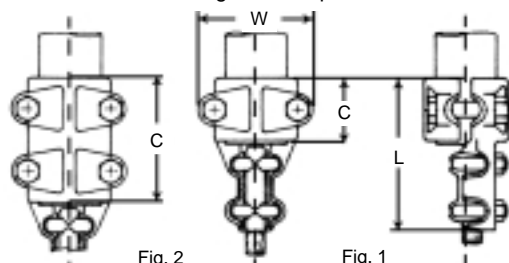

Fig. 2

Fig. 1

Cat. No.	O.D. Tube Run mm	Conductor Range		Fig. No.	Dimensions in mm		
		Area mm ²	O.D. mm		C	L	W
E5	12.7	16 - 95	5.10 - 12.60	1	31.7	86.5	42.9
E10	19.1	25 - 95	6.42 - 12.60	1	35.0	88.9	52.4
E15	19.1	35 - 95	7.65 - 12.60	1	35.0	98.4	52.4
E17	22.2	25 - 95	6.42 - 12.60	1	35.0	88.9	54.0
E20	25.4	25 - 95	6.42 - 12.60	1	35.0	88.9	58.8
E25	25.4	35 - 95	7.65 - 12.60	1	35.0	98.4	58.8
E30	25.4	70 - 150	10.70 - 15.75	1	44.5	117.5	68.2
E31C	25.4	150 - 240	15.75 - 20.25	2	60.3	141.3	58.8
E32C	25.4	500 - 630	28.80 - 33.80	2	76.2	190.5	73.0
E33C	30.0	70 - 150	10.70 - 15.75	2	63.5	139.7	47.6
E35	31.8	35 - 95	7.65 - 12.60	1	50.8	117.5	76.2
E40	31.8	70 - 150	10.70 - 15.75	1	50.8	127.0	76.2
E45	31.8	150 - 240	15.75 - 20.25	1	50.8	136.5	76.2
E46	31.8	240 - 400	20.25 - 25.65	2	76.2	168.3	69.9
E50	38.1	35 - 95	7.65 - 12.60	1	50.8	117.5	81.0
E55	38.1	70 - 150	10.70 - 15.75	1	50.8	123.9	81.0
E55C	38.1	70 - 150	10.70 - 15.75	2	76.2	149.3	76.2
E60C	38.1	150 - 240	15.75 - 20.25	2	76.2	155.6	76.2
E65	50.8	35 - 95	7.65 - 12.60	1	50.8	117.5	95.3
E70	50.8	70 - 150	10.70 - 15.75	1	50.8	127.0	95.3
E75	50.8	150 - 240	15.75 - 20.25	1	50.8	130.1	95.3
E80	76.2	35 - 95	7.65 - 12.60	1	57.1	108.0	127.0
E85	76.2	70 - 150	10.70 - 15.75	1	57.1	127.0	127.0
E90	76.2	150 - 240	15.75 - 20.25	1	57.1	142.8	127.0

Fittings on this page have a minimum current rating, in line with the maximum Australian Standard conductor size or busbar size that the fitting can accept.

Aluminium Tee Connector Busbar to Conductor Type AT

A heavy duty tube-to-cable tee connector. The adjustable tap takes a large range of cables which may be clamped before attaching to tubular bus. Materials: Cast aluminium alloy body, stainless steel bolts, U-bolts, washers and nuts.

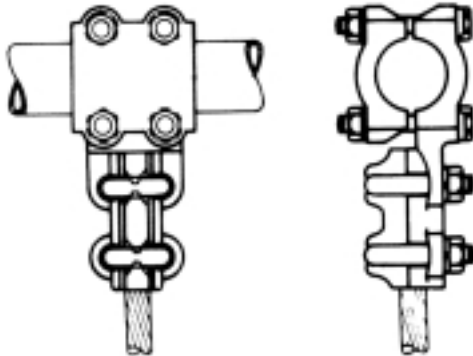

Cat. No.	O.D. Tube mm	Conductor Range	
		mm ²	Dia. Range
AT2550	25.4	35 - 95	7.65 - 12.46
AT1065	25.4	70 - 150	10.70 - 15.75
AT10102	25.4	240 - 400	20.25 - 25.65
AT301521	30.0	175 - 345	15.00 - 21.00
AT3034	30.0	500 - 630	28.80 - 33.80
AT1350	31.8	35 - 95	7.65 - 12.46
AT1465	34.9	70 - 150	10.70 - 15.75
AT14837	34.9	150 - 240	15.75 - 20.25
AT1550	38.1	35 - 95	7.65 - 12.46
AT15837	38.1	150 - 240	15.75 - 20.25
AT15102	38.1	240 - 400	20.25 - 25.65
AT50102	50.0	240 - 400	20.25 - 25.65
AT2065	50.8	70 - 150	10.70 - 15.75
AT2365	57.2	70 - 150	10.70 - 15.75
AT2465	60.3	70 - 150	10.70 - 15.75
AT24102	60.3	240 - 400	20.25 - 25.65
AT3065	76.2	70 - 150	10.70 - 15.75
AT80837	80.0	150 - 240	15.75 - 20.25
AT80102	80.0	240 - 400	20.25 - 25.65
AT3565	88.9	70 - 150	10.70 - 15.75
AT35837	88.9	150 - 240	15.75 - 20.25
AT351339	88.9	500 - 630	28.80 - 32.76
AT100837	100.0	150 - 240	15.75 - 20.25
AT100102	100.0	240 - 400	20.25 - 25.65

Fittings on this page have a minimum current rating, in line with the maximum Australian Standard conductor size or busbar size that the fitting can accept.

Tee Connector Busbar to Conductor

Type T - Copper; Tube run to conductor tap

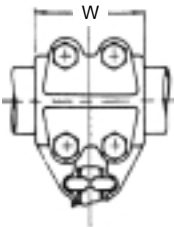

Fig. 2

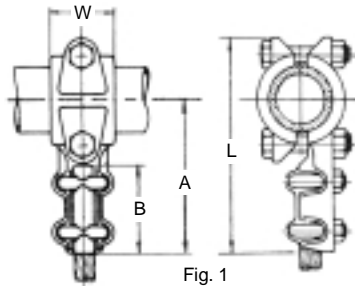

Fig. 1



A heavy duty tube-to-conductor tee connector. The adjustable tap takes a large range of conductors which may be clamped before attaching to tubular bus. Refer to table on adjoining page for conductor ranges and dimensions.

Materials: High copper content alloy casting. Stainless steel U-bolts, bolts, spring washers and nuts.

Tee Connector Busbar to Busbar

Type T - Copper; Tube run to conductor tap

Cat. No.	O.D. Tube Run mm	Conductor Range		Fig. No.	Dimensions mm			
		Area mm ²	O.D. mm		A	B	L	W
T10	19.1	25 - 95	6.42 - 12.46	1	81	51	106	35
T15	19.1	35 - 95	7.65 - 12.60	1	90	60	117	35
T20	25.4	25 - 95	6.42 - 12.46	1	84	50	113	35
T25	25.4	35 - 95	7.65 - 12.60	1	92	60	121	35
T30	25.4	70 - 150	10.70 - 15.75	1	106	70	142	44
T31C	25.4	150 - 240	15.75 - 20.25	2	110	80	140	60
T33	30.2	70 - 150	10.70 - 15.75	1	106	70	140	44
T35	31.8	35 - 95	7.65 - 12.60	1	103	60	142	51
T40	31.8	70 - 150	10.70 - 15.75	1	110	70	146	51
T45	31.8	150 - 240	15.75 - 20.25	1	117	76	156	51
T46	31.8	240 - 400	20.25 - 25.65	2	121	83	156	70
T48	34.1	70 - 150	10.70 - 15.75	1	110	73	148	51
T50	38.1	35 - 95	7.65 - 12.60	1	106	60	146	51
T55	38.1	70 - 150	10.70 - 15.75	1	113	70	152	51
T55C	38.1	70 - 150	10.70 - 15.75	2	111	70	148	76
T60	38.1	150 - 240	15.75 - 20.25	1	119	76	159	51
T64	40.0	630 - 800	32.76 - 37.05	2	146	102	192	80
T65	50.8	35 - 95	7.65 - 12.60	1	111	60	156	51
T69	48.4	70 - 150	10.70 - 15.75	1	118	70	164	51
T70	50.8	70 - 150	10.70 - 15.75	1	121	70	168	51
T75	50.8	150 - 240	15.75 - 20.25	1	127	76	175	51
T77	60.3	70 - 150	10.70 - 15.75	1	130	70	187	57
T80	76.2	35 - 95	7.65 - 12.60	1	127	60	191	57
T85	76.2	70 - 150	10.70 - 15.75	1	137	70	200	57
T90	76.2	150 - 240	15.75 - 20.25	1	140	76	206	57
T105	88.9	150 - 240	15.75 - 20.25	1	151	80	222	64

Fittings on this page have a minimum current rating, in line with the maximum Australian Standard conductor size or busbar size that the fitting can accept.

Straight Connector Conductor to Conductor

Type SC - Copper

Suitable for sub-station applications which require rugged and vibration proof connections. The longitudinal wave cast in both connector base and clamping bar assures high pull-out strength. Connectors are supplied with stainless steel U-bolts and nuts.

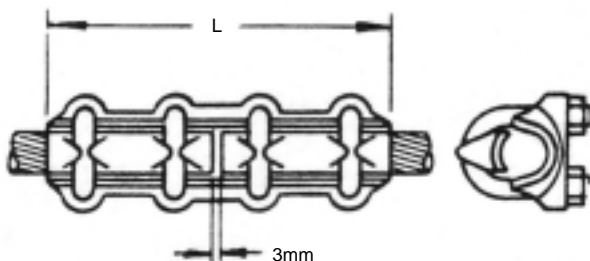

Cat. No.	Conductor Range				Dimension L mm
	Run		Tap		
	Area mm ²	O.D.	Area mm ²	O.D.	
SC1	16 - 35	5.10 - 7.65	16 - 35	5.10 - 7.65	79
SC2	25	6.42	25	6.75	105
SC3	35 - 95	7.65 - 12.46	35 - 95	7.65 - 12.60	127
SC4	70 - 150	10.70 - 15.75	25	6.75	127
SC5	70 - 150	10.70 - 15.75	70 - 150	10.70 - 15.75	143
SC7	150 - 240	15.75 - 20.25	25	6.75	149
SC8	150 - 240	15.75 - 20.25	70 - 150	10.70 - 15.75	149
SC9	150 - 240	15.75 - 20.25	150 - 240	15.75 - 20.25	156

Fittings on this page have a minimum current rating, in line with the maximum Australian Standard conductor size or busbar size that the fitting can accept.

Aluminium Tee Connector Conductor to Conductor Type ATC

A high strength aluminium alloy tee connector for all aluminium and SCA run and tap conductors. U-bolts and nuts are stainless steel.

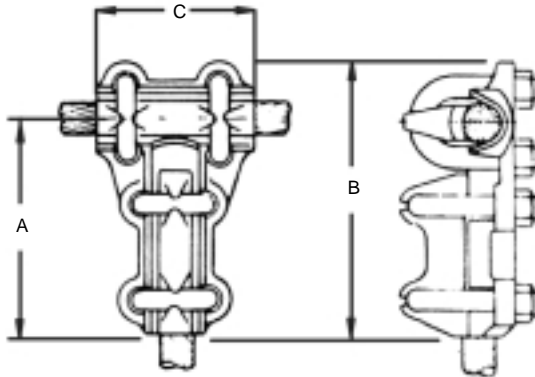

Cat. No.	Conductor Range OD mm		Dimensions mm		
	Run	Tap	A	B	C
ATC2	6.17 - 11.35	6.17 - 11.35	71	94	51
ATC5	10.20 - 16.30	10.20 - 16.30	92	116	70
ATC8	16.30 - 21.00	10.20 - 16.30	111	137	83
ATC9	16.30 - 21.00	16.30 - 21.00	110	136	83
ATC10	21.00 - 26.50	16.30 - 21.00	119	156	89
ATC12	21.00 - 26.50	21.00 - 26.50	127	165	89
ATC13	25.40 - 22.80	16.30 - 21.00	116	157	102
ATC15	25.40 - 33.80	25.40 - 33.80	130	170	89

Fittings on this page have a minimum current rating, in line with the maximum Australian Standard conductor size or busbar size that the fitting can accept.

Tee Connector Conductor to Conductor

Type TC - Copper

Designed for substation applications such as strain buses, suspension of long droppers and for making important tee-off connections which require rugged and vibration- proof connectors. The longitudinal wave cast in both the connector base and clamping bar assures high pull-out strength. Connectors are supplied with stainless steel U-bolts, and nuts.

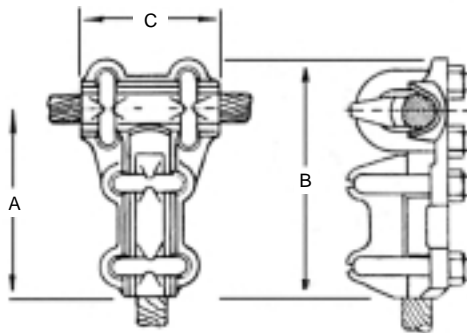

Cat. No.	Conductor Range				Dimensions mm		
	Run		Tap		A	B	C
	Area mm ²	O.D.	Area mm ²	O.D.			
TC1	16 - 35	5.10 - 7.65	10 - 35	5.10 - 7.65	60	79	38
TC2	25 - 70	6.42 - 10.70	25 - 70	6.42 - 10.70	70	90	51
TC3	35 - 95	7.65 - 12.60	35 - 95	7.65 - 12.60	83	103	60
TC4	70 - 150	10.70 - 15.75	25 - 70	6.42 - 10.70	75	98	70
TC5	70 - 150	10.70 - 15.75	70 - 150	10.70 - 15.75	92	116	70
TC6	70 - 150	10.70 - 15.75	150 - 240	15.75 - 20.25	95	122	70
TC7	150 - 240	15.75 - 20.25	25 - 70	6.42 - 10.70	76	105	76
TC8	150 - 240	15.75 - 20.25	70 - 150	10.70 - 15.75	95	122	76
TC9	150 - 240	15.75 - 20.25	150 - 240	15.75 - 20.25	102	127	76
TC12	240 - 400	20.25 - 25.65	240 - 400	20.25 - 25.65	121	156	83
TC20	500 - 630	28.80 - 32.76	500 - 630	28.80 - 33.80	140	178	102

Fittings on this page have a minimum current rating, in line with the maximum Australian Standard conductor size or busbar size that the fitting can accept.

Bolted Tee Connector Conductor to Conductor

Type BRCT - Bolted run, compression tee

Material: Die cast aluminium body with tubular aluminium barrel section, argon arc welded to form Tee Connector. Suitable for AAC, AAAC and ACSR conductors from 20mm dia. up to 34mm dia. through the bolted run and from 14mm up to 34mm for the tap connection. Other types available, see pages XX - XX and consult Dulmison for further details.



Cat. No.	Run Connector		Tap Connector	
	Range	Type	Range	Type
BRCT1	54/7/3.25 61/3.25	ACSR AAC, AAAC	61/3.25	AAC, AAAC
BRCT2	54/3.75 + 19/2.25 61/3.75	ACSR AAC, AAAC	61/3.75	AAC, AAAC
BRCT3	54/3.75 + 19/2.25 61/3.75	ACSR AAC, AAAC	54/3.75 + 19/2.25	ACSR
BRCT4	30/7/3.5	ACSR	30/7/3.5	ACSR
BRCT5	54/3.75 + 19/2.25	ACSR	61/3.75	AAC, AAAC
BRCT6	54/7/3.5	ACSR	54/7/3.5	ACSR

Fittings on this page have a minimum current rating, in line with the maximum Australian Standard conductor size or busbar size that the fitting can accept.

Aluminium Terminal Lug Conductor to Palm

Types AN & AN-B22

A clamp-type aluminium alloy terminal which accommodates a broad range of aluminium, copper and SCA conductors.

Type AN75 is normally supplied with blank palm. 1 or 2 bolt drillings can be supplied to customers' specifications.

Type AN93-B22 through AN134-B22 has four 14mm holes drilled at 50mm centres. Other drillings on request.

Heads of bolts are captured to permit single spanner installation. Suitable for use on copper or aluminium terminal pads when installed with Alminox. Standard hardware is stainless steel.

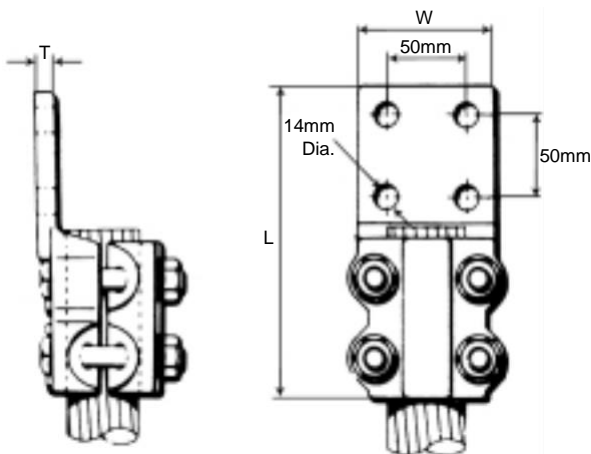

Cat. No.	Conductor Range		Dimensions			No. of Holes
	mm ²	O.D. mm	L mm	W mm	P mm	
AN75	35 - 185	7.65 - 17.64	149	44	85	---
AN93B22	150 - 300	15.75 - 22.68	171	83	89	4
AN113B22	300 - 500	22.68 - 28.80	179	83	96	4
AN134B22	500 - 630	28.80 - 33.80	188	83	95	4

Fittings on this page have a minimum current rating, in line with the maximum Australian Standard conductor size or busbar size that the fitting can accept.

Terminal Lug Conductor to Palm Type NT - Copper

The type NT terminal lug is designed for use with imported switchgear having the NEMA standard terminal drilling. Castings are of high copper content alloy. Bolts, nuts and spring washers are stainless steel.

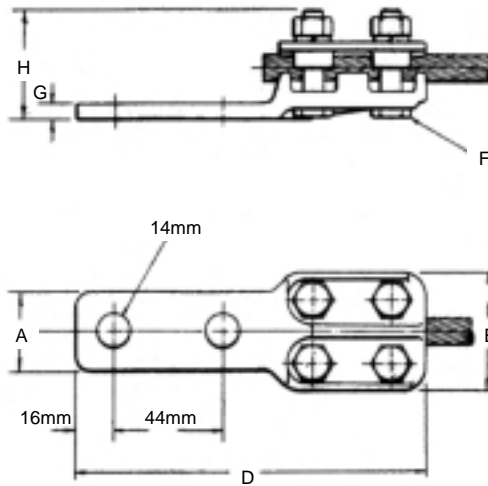

Cat. No.	Conductor Range		Dimensions mm					
	Area mm ²	O.D.	A	D	E	F	G	H
NT1	16 - 70	5.10 - 10.70	32	129	49	M10	6	40
NT2	70 - 150	10.70 - 15.75	38	129	56	M10	8	46
NT3	150 - 240	15.75 - 20.25	44	146	62	M10	10	52
NT4	240 - 400	20.25 - 25.65	54	152	76	M12	13	59
NT5	400 - 630	25.65 - 33.80	64	159	83	M12	13	65

Fittings on this page have a minimum current rating, in line with the maximum Australian Standard conductor size or busbar size that the fitting can accept.

Terminal Lug Conductor to Palm

Type TL - Copper; ATL - Aluminium

A high compression lug particularly suited to connection subject to vibration and strain. The longitudinal wave case of both lug and clamping bar assures high pullout strength. Supplied with stainless steel hardware.

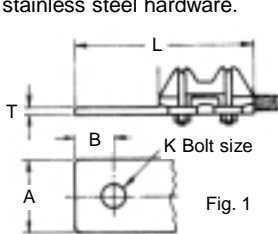

Fig. 1

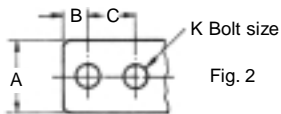

Fig. 2

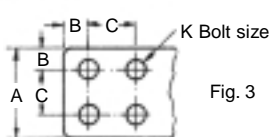

Fig. 3



Cat. No.	Conductor Range		Fig. No.	Dimensions mm					
	Area mm ²	O.D.		A	B	C	K	T	L
TL0	16 - 35	5.10 - 7.65	1	25	13	---	M10	6	67
TL0 2B1	16 - 35	5.10 - 7.65	1	50	25	---	M10	7	92
TL0 187	16 - 35	5.10 - 7.65	2	25	13	48	M10	7	113
TL1	25 - 70	6.75 - 10.70	2	32	13	29	M10	6	105
TL2	35 - 95	7.65 - 12.60	2	32	13	29	M10	8	117
TL2 150	35 - 95	7.65 - 12.60	2	32	16	38	M10	9	137
TL2 187	35 - 95	7.65 - 12.60	2	32	13	48	M10	9	137
TL2 200	35 - 95	7.65 - 12.60	2	32	16	50	M12	9	149
TL2 B1	35 - 95	7.65 - 12.60	1	44	22	---	M20	9	108
TL3	70 - 150	10.70 - 15.75	2	35	16	38	M12	10	140
TL3 B22	70 - 150	10.70 - 15.75	3	79	14	50	M12	8	160
TL3 187	70 - 150	10.70 - 15.75	2	35	16	48	M12	10	149
TL3 2B1	70 - 150	10.70 - 15.75	1	50	25	---	M10	9	127
TL3 B4	70 - 150	10.70 - 15.75	3	64	13	38	M10	7	137
TL3 B22C	70 - 150	10.70 - 15.75	3	102	25	50	M12	14	181
TL4	150 - 240	15.75 - 20.25	2	38	16	38	M12	10	146
TL4 B22	150 - 240	15.75 - 20.25	3	83	16	50	M12	10	165
TL4 187	150 - 240	15.75 - 20.25	2	38	16	48	M12	10	156
TL4 B4	150 - 240	15.75 - 20.25	3	64	13	38	M10	8	140
TL4 B5	150 - 240	15.75 - 20.25	3	76	13	50	M10	7	159
TL5	240 - 400	20.25 - 25.65	2	41	16	38	M12	13	156
TL5 B22	240 - 400	20.25 - 25.65	3	83	16	50	M12	10	173
TL5 187	240 - 400	20.25 - 25.65	2	41	16	48	M12	13	165
TL5 B4	240 - 400	20.25 - 25.65	3	76	19	38	M10	9	165
TL5 B5	240 - 400	20.25 - 25.65	3	76	13	50	M10	9	165
TL6	400 - 500	25.65 - 28.80	2	48	19	38	M12	14	165
TL6 B22	400 - 500	25.65 - 28.80	3	83	16	50	M12	9	176
TL7	500 - 630	28.80 - 32.76	2	48	19	38	M12	16	178
TL7 B22	500 - 630	28.80 - 32.76	3	83	16	50	M12	11	187
TL7 B4	500 - 630	28.80 - 32.76	3	76	19	38	M10	10	184
TL7 B5	500 - 630	28.8 - 32.76	3	76	13	50	M10	10	184

Note: To order in aluminium, add prefix 'A' to catalogue number.

Fittings on this page have a minimum current rating, in line with the maximum Australian Standard conductor size or busbar size that the fitting can accept.

Right Angle Terminal Lug Conductor to Palm

Type TLC - Copper; ATLC - Aluminium

For use when terminating conductors at right angles to switchgear terminal plates. Castings are in high copper content alloy. U-bolts, nuts and spring washers are stainless steel.

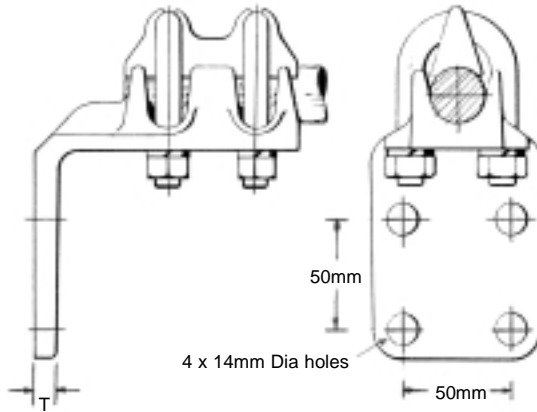

Cat. No.	Conductor Range		Dimension T mm
	Area mm ²	O.D.	
TL3C22	70 - 150	10.70 - 15.75	8
TL4C22	150 - 240	15.75 - 20.25	10
TL7C22	500 - 630	28.80 - 33.80	11

Note: To order in aluminium, add prefix 'A' to catalogue number.

Fittings on this page have a minimum current rating, in line with the maximum Australian Standard conductor size or busbar size that the fitting can accept.

Terminal Lug Stud or Busbar to Palm

Type CS - Copper

For the connection of vertical tubular busbar to switchgear terminal plates. Also used on equipment studs to provide a flat contact palm.

Materials: Terminal lugs are cast in high copper content alloy. Bolts, nuts and spring washers are stainless steel.

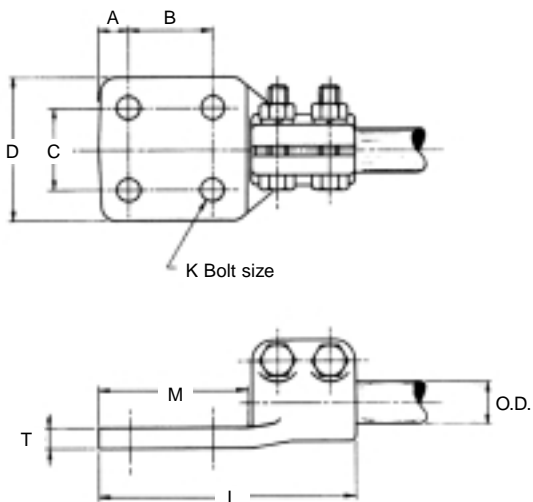

Cat. No.	O.D. Tube mm	Dimensions mm							
		A	B	C	D	L	M	T	K
CS5	19.1	16	51	51	83	130	83	10	M12
CS20	25.4	16	51	51	83	149	83	13	M12
CS20B	25.4	19	38	38	83	149	83	13	M10
CS112	28.6	16	38	38	76	149	76	10	M12
CS28	30.2	---	---	---	76	146	76	10	M12
CS28C	30.2	25	51	51	102	171	108	13	M12
CS30C	31.8	25	51	51	102	171	108	13	M12
CS38	34.9	25	51	51	102	171	105	13	M12
CS40C	38.1	25	51	51	102	171	105	13	M12
CS42	39.7	25	51	51	102	171	105	13	M12
CS42A	39.7	35	70	70	140	210	143	13	M16
CS181	46.0	25	38	51	102	178	105	16	M12
CS231	58.7	25	38	51	102	203	108	19	M12
CS250	63.5	25	38	51	102	203	108	19	M12

Fittings on this page have a minimum current rating, in line with the maximum Australian Standard conductor size or busbar size that the fitting can accept.

Palmless Connector

Types PC & PCS - Copper; APC & APCS - Aluminium

Low cost connectors for clamping cable to switchgear terminal plates with four 14mm diameter holes at 50mm centres. Castings are of high copper content alloy. U-bolts, nuts and spring washers are stainless steel.

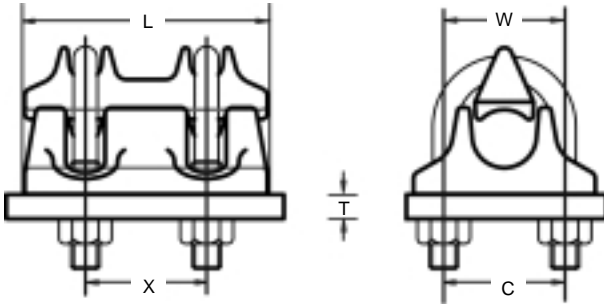

Cat. No.	Cable Range		Dimensions mm					No. of Holes
	Area mm ²	O.D.	C	L	T	W	X	
*PCS1	25 - 120	6.75 - 14.21	22	32	7	44	---	2 x 9.5
*PCS2	50 - 300	8.90 - 22.68	33	38	7	50	---	2 x 11.5
PC3	70 - 150	10.70 - 16.00	50	102	13	76	50	4 x 14.0
PC4	150 - 240	15.00 - 21.00	50	102	13	76	50	4 x 14.0
PC5	240 - 400	20.00 - 25.65	50	102	13	76	50	4 x 14.0
PC7	500 - 630	28.80 - 33.80	50	102	13	76	50	4 x 14.0

Note: PSC1 & PSC2 are single U-bolt connectors. To order in aluminium, add prefix 'A' to catalogue number.

Fittings on this page have a minimum current rating, in line with the maximum Australian Standard conductor size or busbar size that the fitting can accept.

Flat Busbar Connector

Type BAC - Copper

A 3-bolt 'A' shape connector for end-to-end or tee connecting flat copper busbar. Clamp halves are high strength copper alloy. Bolts and nuts are stainless steel.

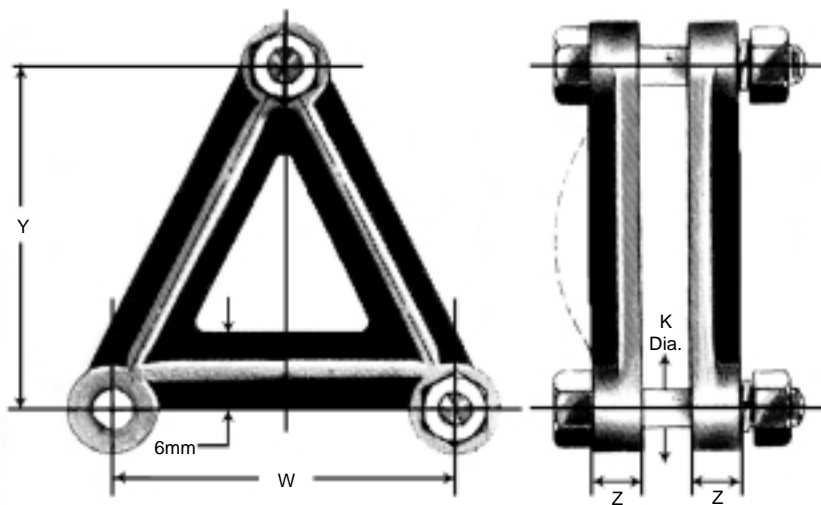

Cat. No.	Width of Busbar mm		Dimensions mm			
	Run	Tap	K	W	Y	Z
BAC5151	50.8	50.8	M10	62	62	13
BAC7651	76.2	50.8	M10	62	87	13
BAC7676	76.2	76.2	M10	87	87	13
BAC10251	101.6	50.8	M12	65	116	14
BAC10276	101.6	76.2	M12	90	116	14
BAC1521	152.4	101.6	M12	117	178	14

Fittings on this page have a minimum current rating, in line with the maximum Australian Standard conductor size or busbar size that the fitting can accept.

Flat Busbar Connector

Type BC - Copper

A heavy duty 4-bolt connector for cross-over, tee or end-to-end jointing of flat copper busbar. Clamp halves are made of high strength copper alloy. Bolts and nuts are stainless steel.

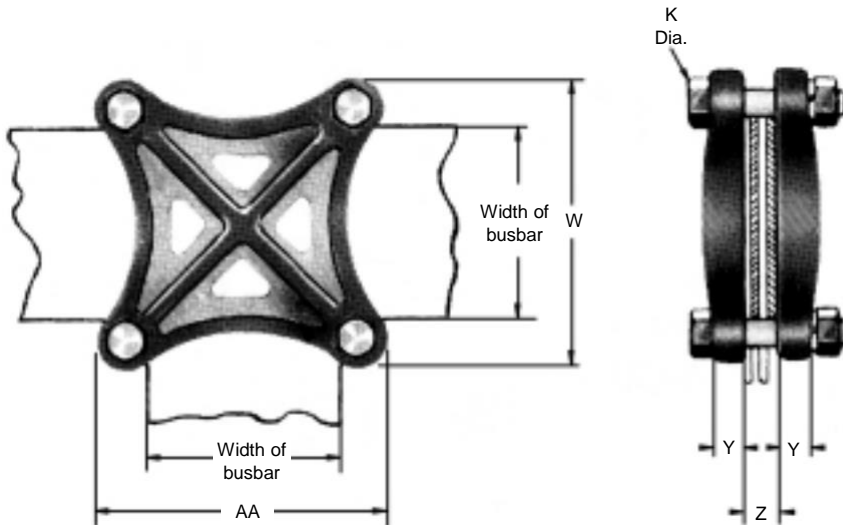

Cat. No.	Width of Busbar mm		Dimensions mm			
	Run 'A'	Tap 'B'	K	W	Y	Z
BC2	50.8	50.8	M10	89	11	19
BC3	76.2	76.2	M10	114	13	32
BC4	101.6	101.6	M12	149	16	32
BC6	152.4	152.4	M16	213	25	32

Note: Dimension 'Z' is standard spacing between connector halves. If greater spacing is required, please specify for determination of bolt length.

Fittings on this page have a minimum current rating, in line with the maximum Australian Standard conductor size or busbar size that the fitting can accept.

